

Spring rings

Retainers for ball transfer units GN 509 / GN 509.1

SPECIFICATION

Types

- Type **A**: Clamp spring washer
- Type **B**: Retaining ring

Type A

Spring steel
Stainless Steel

Type B

Spring steel
zinc plated



INFORMATION

Clamp spring washers GN 509.3, type A allow ball transfers units to be mounted and removed from the installation side.

Retaining rings GN 509.3, type B are mounted from the back. Ball transfers units mounted this way can no longer be dismantled. No restrictions exist with respect to sheet metal thickness.

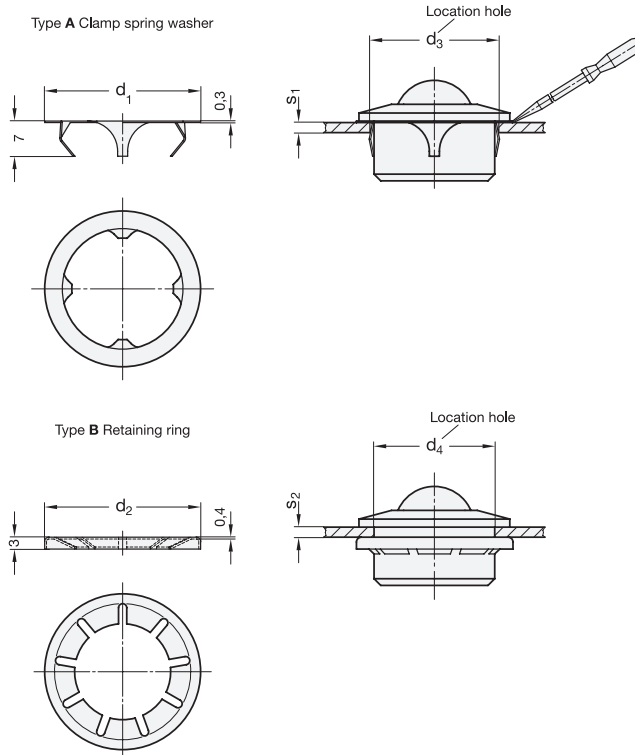

GN 509.3

STAINLESS STEEL

Description	d1	d2	d3	d4	s1	s2	For ball transfer units	⚖️
							GN 509 GN 509.1 Size	
GN 509.3-31-A	31	-	25-0.2	-	2 ... 3	-	15	1
GN 509.3-44-A	44	-	37.3-0.3	-	2 ... 4	-	22	2
GN 509.3-55-A	55	-	46.7-0.3	-	2 ... 4	-	30	2
GN 509.3-36-B	-	36	-	22.2	-	*	12	3
GN 509.3-38-B	-	38	-	24.2	-	*	15	3

* optional



9

Machine elements